

Data sheet | Item number: 285-135

2-conductor through terminal block; 35 mm²; lateral marker slots; only for DIN 35 x 15 rail; 2.3 mm thick; copper; POWER CAGE CLAMP

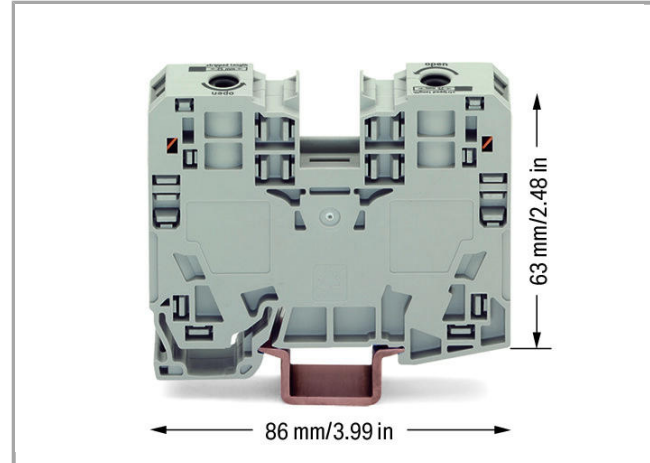

285-135

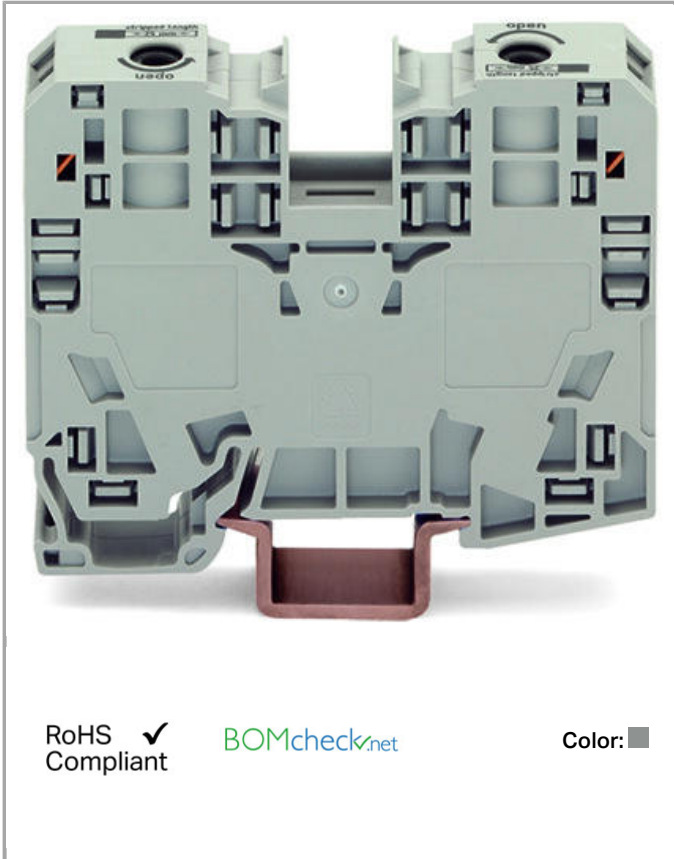

RoHS Compliant

[BOMcheck.net](https://www.bomcheck.net)

Color:

Item description

Safety information 1:

sively on DIN-35 x 15 rail

Data

Electrical data

Ratings per IEC/EN 60664-1

Rated voltage (III / 3)	1000 V
Rated impulse voltage (III / 3)	8 kV
Rated current	125 A

Connection data

Connection technology	POWER CAGE CLAMP
-----------------------	------------------

Actuation type	Operating tool
Connectable conductor materials	Copper
Solid conductor	6 ... 35 mm ² / 10 ... 2 AWG
Fine-stranded conductor	6 ... 35 mm ² / 10 ... 2 AWG
Strip length	25 mm / 0.98 inch
Total number of connection points	2
Total number of potentials	1
Number of levels	1
Type of wiring	Side-entry wiring

Geometrical Data

Width	16 mm / 0.63 inch
Height from upper-edge of DIN-35 rail	63 mm / 2.48 inch
Depth	86 mm / 3.386 inch

Mechanical data

Design	horizontal
Type of mounting	DIN-35 rail
Marking level	Side marking

Material Data

Color	gray
Insulating material	Polyamide 66 (PA 66)
Fire load	1.246 MJ
Weight	79.349 g

Commercial data

Product Group	1 (Rail Mounted Terminal Blocks)
Country of origin	PL
GTIN	4045454507381
Customs Tariff No.	85369010000

Approvals / Certificates

Country specific Approvals

Logo	Approval	Additional Approval Text	Certificate name
	CCA DEKRA Certification B.V.	EN 60947	NTR NL- 7707
	CSA	C22.2 No. 158	1151144



DEKRA Certification B.V.



KEMA/KEUR



EN 60947

DEKRA Certification B.V.

71-

101911

Ship Approvals



Logo	Approval	Additional Approval Text	Certificate name
	ABS American Bureau of Shipping	EN 60947	14- HG1293677- PDA
	LR Lloyds Register	EN 60947	91/20112 (E9)

UL-Approvals

Logo	Approval	Additional Approval Text	Certificate name
	UL Underwriters Laboratories Inc.	UL 1059	E45172

Compatible products

Jumper

	Item no.: 285-430 Step-down jumper; insulated; from 285-13x to 2010 and 2016 Series TOPJOB®S terminal blocks; Nominal current 90 A	285-430
	Item no.: 285-435 Adjacent jumper; insulated; Nominal current 85 A	285-435

potential distribution

	Item no.: 283-407 Power tap; with 500 mm cable; for 16 mm ² (283/783 Series) and 35 mm ²	283-407
---	--	---------

protection



Item no.: 285-420
Protective warning marker; with high-voltage symbol, black

285-420



Item no.: 285-421
Finger guard; touchproof cover protects unused conductor entries; for 35 mm² high-current tbs

285-421

General accessories



Item no.: 249-105
Group marker carrier

249-105



Item no.: 283-404
Test plug adapter; 11.6 mm wide; for 4 mm Ø test plugs; suitable for 1.5 mm² - 16 mm² tbs

283-404



Item no.: 285-427
Power tap; for 35 mm² high-current tbs; Module width 8 mm

285-427

assembling



Item no.: 210-148
Angled support bracket; without screw

210-148



Item no.: 249-117
Screwless end stop; 10 mm wide; for DIN-rail 35 x 15 and 35 x 7.5

249-117



Item no.: 249-197
Screwless end stop; 14 mm wide; for DIN-rail 35 x 15 and 35 x 7.5

249-197

tools



Item no.: 210-721
Operating tool with partially insulated shaft; Type 3, blade (5.5 x 0.8) mm

210-721

ferrule



Item no.: 216-413
Ferrule; Sleeve for 25 mm² / AWG 4; uninsulated; electro-tin plated; electrolytic copper; gastight crimped; acc. to DIN 46228, Part 1/08.92

216-413



Item no.: 216-414
Ferrule; Sleeve for 35 mm² / AWG 2; uninsulated; electro-tin plated; electrolytic copper; gastight crimped; acc. to DIN 46228, Part 1/08.92

216-414

Marking accessories



Item no.: 2009-110
Marking strips; on reel; not stretchable; plain; snap-on type

2009-110



Item no.: 2009-115
WMB-Inline; for Smart Printer; on reel; stretchable 5 - 5.2 mm; plain; snap-on type

2009-115



Item no.: 2009-115/000-002
WMB-Inline; for Smart Printer; on reel; stretchable 5 - 5.2 mm; plain; snap-on type

2009-115

/000-002



Item no.: 2009-115/000-005
WMB-Inline; for Smart Printer; on reel; stretchable 5 - 5.2 mm; plain; snap-on type

2009-115















/000-005





Item no.: 2009-115/000-006
WMB-Inline; for smartPRINTER; on reel; stretchable 5 - 5.2 mm; plain; snap-on type

2009-115

/000-006

	Item no.: 2009-115/000-007 WMB-Inline; for Smart Printer; on reel; stretchable 5 - 5.2 mm; plain; snap-on type	/000-007	2009-115
	Item no.: 2009-115/000-012 WMB-Inline; for smartPRINTER; on reel; stretchable 5 - 5.2 mm; plain; snap-on type	/000-012	2009-115
	Item no.: 2009-115/000-017 WMB-Inline; for Smart Printer; on reel; stretchable 5 - 5.2 mm; plain; snap-on type	/000-017	2009-115
	Item no.: 2009-115/000-023 WMB-Inline; for Smart Printer; on reel; stretchable 5 - 5.2 mm; plain; snap-on type	/000-023	2009-115
	Item no.: 2009-115/000-024 WMB-Inline; for smartPRINTER; on reel; stretchable 5 - 5.2 mm; plain; snap-on type	/000-024	2009-115
	Item no.: 285-442 Adaptor		285-442
	Item no.: 793-501 WMB marking card; as card; not stretchable; plain; snap-on type		793-501
	Item no.: 793-501/000-002 WMB marking card; as card; not stretchable; plain; snap-on type	/000-002	793-501
	Item no.: 793-501/000-005 WMB marking card; as card; not stretchable; plain; snap-on type	/000-005	793-501
	Item no.: 793-501/000-006 WMB marking card; as card; not stretchable; plain; snap-on type	/000-006	793-501
	Item no.: 793-501/000-007 WMB marking card; as card; not stretchable; plain; snap-on type	/000-007	793-501
	Item no.: 793-501/000-012 WMB marking card; as card; not stretchable; plain; snap-on type	/000-012	793-501
	Item no.: 793-501/000-017 WMB marking card; as card; not stretchable; plain; snap-on type	/000-017	793-501
	Item no.: 793-501/000-023 WMB marking card; as card; not stretchable; plain; snap-on type	/000-023	793-501
	Item no.: 793-501/000-024 WMB marking card; as card; not stretchable; plain; snap-on type	/000-024	793-501
	Item no.: 793-5501		

	WMB marking card; as card; for terminal block width 5 - 17.5 mm; stretchable 5 - 5.2 mm; plain; snap-on type	793-5501
--	--	----------

	Item no.: 793-5501/000-002 WMB marking card; as card; for terminal block width 5 - 17.5 mm; stretchable 5 - 5.2 mm; plain; snap-on type	793-5501 /000-002
--	---	----------------------

	Item no.: 793-5501/000-005 WMB marking card; as card; stretchable 5 - 5.2 mm; plain; snap-on type	793-5501 /000-005
--	---	----------------------

	Item no.: 793-5501/000-006 WMB marking card; as card; stretchable 5 - 5.2 mm; plain; snap-on type	793-5501 /000-006
--	---	----------------------

	Item no.: 793-5501/000-007 WMB marking card; as card; stretchable 5 - 5.2 mm; plain; snap-on type	793-5501 /000-007
--	---	----------------------

	Item no.: 793-5501/000-012 WMB marking card; as card; stretchable 5 - 5.2 mm; plain; snap-on type	793-5501 /000-012
--	---	----------------------

	Item no.: 793-5501/000-014 WMB marking card; as card; stretchable 5 - 5.2 mm; plain; snap-on type	793-5501 /000-014
--	---	----------------------

	Item no.: 793-5501/000-017 WMB marking card; as card; stretchable 5 - 5.2 mm; plain; snap-on type	793-5501 /000-017
--	---	----------------------

	Item no.: 793-5501/000-023 WMB marking card; as card; stretchable 5 - 5.2 mm; plain; snap-on type	793-5501 /000-023
--	---	----------------------

	Item no.: 793-5501/000-024 WMB marking card; as card; stretchable 5 - 5.2 mm; plain; snap-on type	793-5501 /000-024
--	---	----------------------

Carrier rail

	Item no.: 210-114 Steel carrier rail; 35 x 15 mm; 1.5 mm thick; 2 m long; unslotted; similar to EN 60715	210-114
--	--	---------

	Item no.: 210-118 Steel carrier rail; 35 x 15 mm; 2.3 mm thick; 2 m long; unslotted; according to EN 60715	210-118
--	--	---------

	Item no.: 210-197 Steel carrier rail; 35 x 15 mm; 1.5 mm thick; 2 m long; slotted; similar to EN 60715	210-197
--	--	---------

	Item no.: 210-198 Copper carrier rail; 35 x 15 mm; 2.3 mm thick; 2 m long; unslotted; according to EN 60715	210-198
--	---	---------

	Item no.: 210-506 Steel carrier rail; 35 x 15 mm; 1.5 mm thick; 2 m long; unslotted; galvanized; similar to EN 60715	210-506
--	--	---------

	Item no.: 210-508 Steel carrier rail; 35 x 15 mm; 1.5 mm thick; 2 m long; slotted; galvanized; similar to EN 60715	210-508
--	--	---------



Downloads

Documentation

Bid Text

285-135	Apr 4, 2012	doc	Download
Reihenklennen		24.1 kB	

CAD/CAE - Smart Data

CAD data

3D Download 285-135	URL	Download
---------------------	-----	----------

Product family

POWER CAGE CLAMP

[Learn more about the product family.](#)

[Show all products from the family](#)

Subject to changes.
